

171X151X51 mm

SUNON

180-200 CFM



| Model | P/N | Bearing | Rating Voltage (VAC) | Freq. (Hz) | Power Current (AMP) | Power Consumption (WATTS) | Speed (RPM) | Air Flow (CFM) | Static Pressure (Inch-H ₂ O) | Noise (dBA) | Weight (g) |
|-----------|------|---------|----------------------|------------|---------------------|---------------------------|-------------|----------------|---|-------------|------------|
| A1175-HBL | T.GN | ○ BALL | 115 | 50/60 | 0.59/0.48 | 39/36 | 2650/2950 | 180/200 | 0.48/0.38 | 52/55 | 957 |
| A1175-HBT | T.GN | ○ BALL | 115 | 50/60 | 0.59/0.48 | 39/36 | 2650/2950 | 180/200 | 0.48/0.38 | 52/55 | 957 |
| A2175-HBL | T.GN | ○ STEEL | 220-240 | 50/60 | 0.28/0.24 | 39/36 | 2650/2950 | 180/200 | 0.48/0.38 | 52/55 | 957 |
| A2175-HBT | T.GN | ○ STEEL | 220-240 | 50/60 | 0.28/0.24 | 39/36 | 2650/2950 | 180/200 | 0.48/0.38 | 52/55 | 957 |

Frame : Aluminum alloy

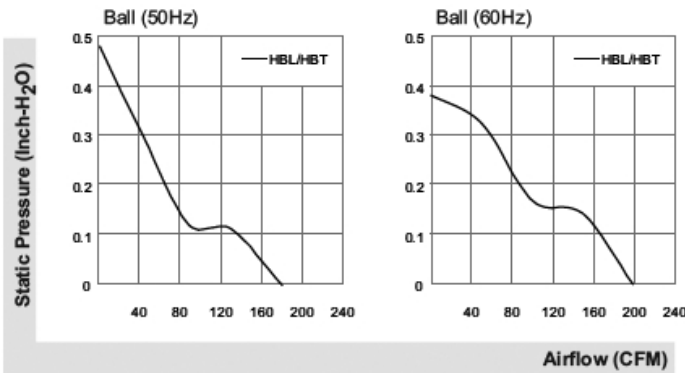

UNITS:mm

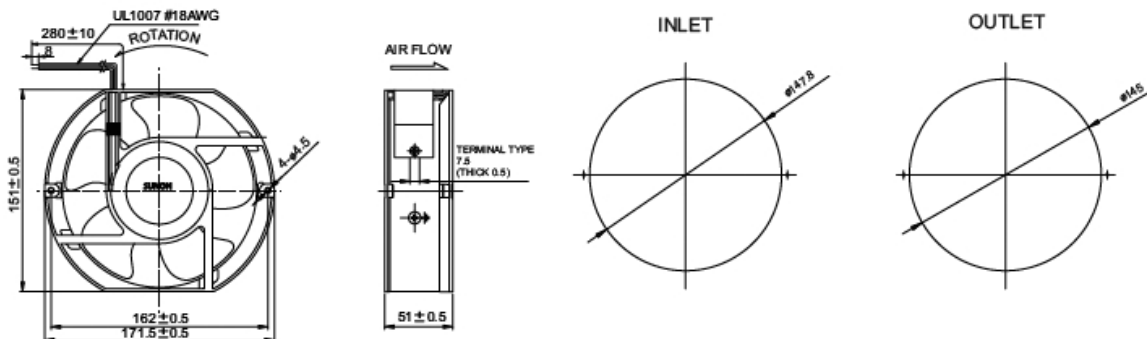

*All model could be customized on voltage or any other requirements to fit your need.

*Specifications subject to change without notice. Please Visit SUNON web site at <http://www.sunon.com> for update information.